

Genesis[™] 7580

Presentation Area Imager

User's Guide

Disclaimer

Honeywell International Inc. ("HII") reserves the right to make changes in specifications and other information contained in this document without prior notice, and the reader should in all cases consult HII to determine whether any such changes have been made. The information in this publication does not represent a commitment on the part of HII.

HII shall not be liable for technical or editorial errors or omissions contained herein: nor for incidental or consequential damages resulting from the furnishing, performance, or use of this manual.

This document contains propriety information that is protected by copyright. All rights reserved. No part of this document may be photocopied, reproduced, or translated into another language without the prior written consent of HII.

© 2010 - 2011 Honeywell International Inc. All rights reserved.

Web Address: www.honeywellaidc.com

Trademarks

Omniplanar, Swiftdecoder, Metrologic, MetroSet2, and TotalFreedom are trademarks or registered trademarks of Metrologic Instruments, Inc. or Honeywell International Inc.

Microsoft, Windows 95, and Windows are registered trademarks of Microsoft Corporation.

IBM is a trademark of International Business Machines Corporation.

Checkpoint is a registered trademark of Checkpoint Systems, Inc.

Other product names mentioned in this manual may be trademarks or registered trademarks of their respective companies and are the property of their respective owners.

Patents

For patent information, please refer to www.honeywellaidc.com/patents.



Table of Contents

Introduction

Product Overview	1
Base Kit Components.....	2
Optional Accessories.....	2
MS7580 Components.....	4
Labels.....	5
Maintenance.....	5
Cable Installation and Removal.....	6

Interface Installation

RS232	7
Keyboard Wedge.....	8
RS485	9
USB.....	10

Mounting the MS7580

Components of Adapter Kit 46-00911	13
Components of Wall Mount Kit 46-00913.....	13
Installation of Adapter Kit 46-00911	14
Installation of Wall Mount Kit 46-00913	16

Operation

Modes of Operation.....	17
Audible Indicators.....	19
Visual Indicators	20
Failure Modes.....	21
Field of View.....	22
Depth of Field by Minimum Bar Code Element Width	23
IR Activation Range.....	24
Illumination Source.....	25
IR Source	26
Targeting Source.....	27

Troubleshooting Guide	29
Design Specifications	33
Applications and Protocols	35
Configuration and Upgrades	37
Configuration Modes	37
Upgrading the Firmware	37
MS7580-124-EAS Model	
Integrated RF EAS Antenna Connection	39
EAS System Connection	40
Configuration for EAS Applications	42
EAS Tag Deactivation Range.....	44
Imager Pinouts–MS7580-124-EAS	46
Cable Pinouts	47
Antenna Disconnect	47
Imager and Cable Terminations	
Standard Imager Pinouts.....	49
Standard Cable Pinouts.....	50
Limited Warranty	53
Regulatory Compliance	
Safety	55
EMC	56
Index	59
Customer Support	61
Technical Assistance.....	61
Product Service and Repair.....	62

Introduction

Product Overview

The MS7580 Genesis™ is a high performance presentation area-imaging bar code imager that utilizes CMOS imaging sensors for superior image quality. Genesis utilizes custom decoder software, for reliable decoding of both 1D and 2D bar code symbologies. Sharp images can be captured and transmitted in a variety of outputs including: .jpg, .bmp, and .tiff.

Omnidirectional scanning capabilities and an excellent motion tolerance provides aggressive scanning of all standard 1D, GS1 DataBar™ (RSS), PDF417, microPDF, Composite, Matrix, and Postal Codes symbology types. Firmware updates are easily loaded into Flash memory.

The MS7580 provides an extended scan volume and a built in object detection sensor (IR) that instantly turns on the imager when an object is presented within the imager's field of view.

Genesis™	Interface Support
MS7580-124*	<p>Interfaces supported include:</p> <ul style="list-style-type: none">• RS232• USB♦• Keyboard Wedge• RS485◇ (External via Cable)
<p>* EAS equipped models are indicated with an EAS extension on the model number (i.e., MS7580-124-EAS). See pages 39–47 for additional product information.</p> <p>♦ USB is configurable for Keyboard Emulation Mode, Bi-Directional Serial Emulation Mode or IBM OEM. The default USB setting is Keyboard Emulation Mode.</p> <p>◇ Applicable for IBM® host applications.</p>	
<p>Note: Standard models ship with the ability to read all 1D, PDF, and 2D bar codes. Decoding and functional capability is limited and imagers will not support key features including, but not limited to, the ability to decode PDF, 2D or OCR fonts without proper limited use licenses provided by Honeywell. If you wish to purchase a limited license for one or more of the key features not included in the standard imager, please specify at the time of sale or otherwise contact a customer service representative for more information.</p>	

Base Kit Components

Part #	Description
MS7580-124*	Genesis 7580 Presentation Area Imager
00-02544**	MetroSelect® Single-Line Configuration Guide**
00-05252**	Area-Imaging Supplemental Configuration Guide*
GEN-7580-UG**	Genesis 7580 Installation and User's Guide*
<p>* EAS equipped models are indicated with an EAS extension on the model number (i.e., MS7580-124-EAS). See pages 39–47 for additional product information.</p> <p>** Manuals are available for download from www.honeywellaidc.com.</p>	

Optional Accessories

Part #	Description
AC to DC Power Transformer - Regulated 12VDC @ 1.25A output.	
46-00862	90VAC to 255VAC United States, Canada and Japan
46-00863	90VAC to 255VAC Continental European
46-00864	90VAC to 255VAC United Kingdom
46-00865	90VAC to 255VAC China
46-00866	90VAC to 255VAC Australia

Other items may be ordered for the specific protocol being used. To order additional items, contact the dealer, distributor, or customer service. See page 61 for contact information.

Part #	Description
<p><u>Cable Compatibility Warning</u></p> <p>The MS7580 requires a cable designed for a 12VDC area imager. Do not attempt to use any cables other than the specified cables listed below (<i>cable series 5S-5Sxxx</i>). Any damage incurred from incorrect cable usage will void the limited warranty shown on page 53.</p>	
5S-5S000-3	RS232 12V VLink Cable with Built in Power Jack Straight Black Cable with Short Strain Relief
5S-5S002-3	Keyboard Wedge 12V VLink Cable with Adapter Cable Straight Black Cable with Short Strain Relief
5S-5S213-N-3	USB Direct Cable for 12V Host Power Locking Plus-Power™ Type A Connector Straight Black Cable with Short Strain Relief
5S-5S235-3	USB 12V VLink Cable with Built in Power Jack Non-Locking Type A Connector Straight Black Cable with Short Strain Relief
MX-RS485-5S006-3	RS485 Voltage Converter Cable with Build in Power Jack Straight Black Cable with Short Strain Relief
<p>The following MS7580-124-EAS cables are compatible with Checkpoint® System devices. For additional cable information for the MS7580-124-EAS, refer pages 39–47.</p>	
MX-5S114-E-3	RS232 12V VLink Straight, Black Cable with Built in Power Jack
MX-5S236-E-3	USB 12V VLink Straight Black Cable with Built in Power Jack, Non-Locking Type A Connector
46-00911	MS7580 Wall Mount Adapter Kit
46-00913	MS7580 Wall Mount Kit
00-05250	MS7580 Wall Mount Installation Guide

Other items may be ordered for the specific protocol being used. To order additional items, contact the dealer, distributor, or customer service. See page 61 for contact information.

MS7580 Components

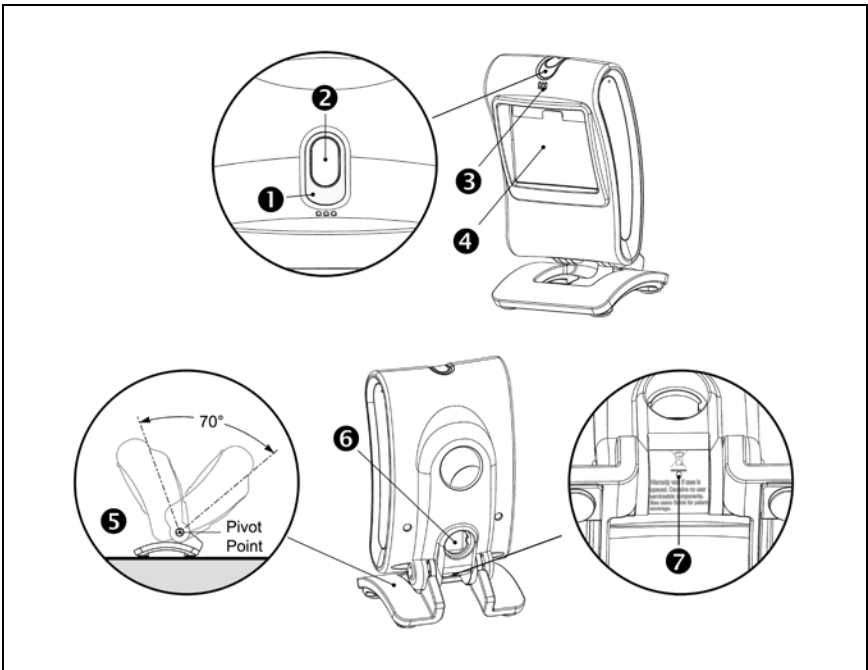

Item	Item Description	
1	Blue and White LED	See <i>Visual Indicators</i> (on page 20)
2	Button	Mode Select Button
3	Speaker	See <i>Audible Indicators</i> (on page 19)
4	Window	LED Aperture
5	Adjustable Base	
6	Cable Connection	10-pin RJ45, Female Socket, See <i>Imager Pinout Connections</i> (on page 49)
7	Cable Release	See <i>Cable Installation and Removal</i> (on page 6)

Note: The MS7580-124-EAS model is equipped with an integrated antenna for Electronic Article Surveillance (EAS) system support. See pages 39–47 for additional product information.

Figure 1. Imager Components

Labels

Each MS7580 has a label located near the top of the output window. This label provides the imager's model number, date of manufacture, serial number, CE and caution information. Additional information has been molded into the underside of the imager's case. The following figure gives an example of the label and the molded text with their locations identified.

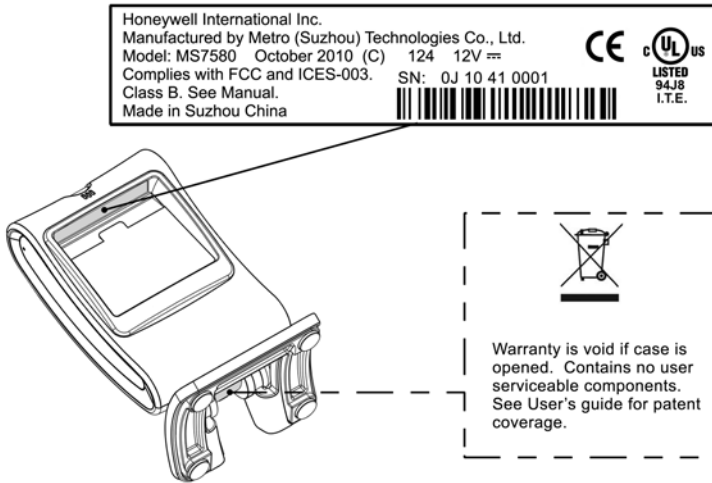

Figure 2. Label and Molded Text Samples



For North America:

CAUTION: To maintain compliance with applicable standards, all circuits connected to the scanner must meet the requirements of a NEC Class 2 power source or Limited Power Source as defined in UL 60950-1 Clause 2.5.

For Other Countries:

CAUTION: To maintain compliance with applicable standards, all circuits connected to the scanner must meet the requirements of a Limited Power Source as defined in IEC 60950-1 Clause 2.5.

Maintenance

Smudges and dirt on the imager's window can interfere with the imager's performance. If the window requires cleaning, use only a mild glass cleaner containing no ammonia. When cleaning the window, spray the cleaner onto a lint free, non-abrasive cleaning cloth and then gently wipe the window clean.

If the imager's case requires cleaning, use a mild cleaning agent that does not contain strong oxidizing chemicals. Strong cleaning agents may discolor or damage the imager's exterior.

Cable Installation and Removal

Installation

1. Insert the cable's modular connector into the socket on the imager.
2. Pull gently on the cable strain relief to ensure the cable is installed.

Note: If the cable is not fully latched, the imager may power intermittently.

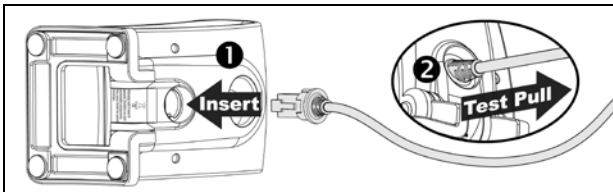

Figure 3. Installing the Cable

Removal

Turn the host power off and disconnect the power supply from the cable before attempting to disconnect the cable from the imager.

1. Locate the small pinhole on the imager near the cable connection point.
2. Bend a paperclip into the shape shown below.
3. Insert the paperclip into the pinhole and apply pressure to release the connector lock.
4. Pull gently on the strain-relief of the cable to remove the cable from the imager.

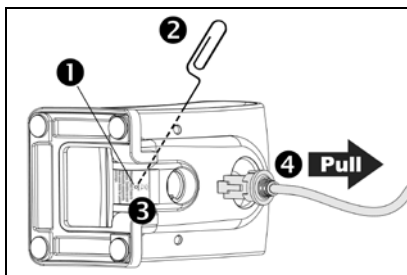

Figure 4. Disconnecting the Cable

MS7580-124-EAS Model Note

See page 39 for additional cable installation/removal instructions specific to the MS7580-124-EAS Genesis with integrated RF EAS antenna.

Interface Installation

RS232

1. Turn off power to the host device.
2. Plug the interface cable's modular connector into the socket on the imager.
3. Connect the other end of the cable to a dedicated COM port on the host device.
4. Plug the 12V power supply♦ into the power jack on the cable.
5. Check the AC input requirements of the power supply to verify the voltage matches the AC outlet. The outlet must be located near the equipment and easily accessible.
6. Connect AC power♦ to the transformer.
7. The MS7580 will start to initialize. The white and blue LED will alternately fade on and off for three seconds. When the imager has finished initializing, the imager will flash the white LED three times while simultaneously beeping three times. The low intensity blue LED will remain turned on.
8. Turn on power to the host device.

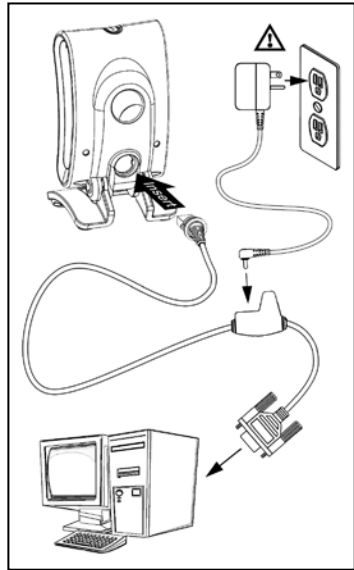

Figure 5. RS232



See caution on page 5.

Installation Notes

- MS7580-124-EAS models are equipped with an integrated RF EAS antenna. See page 39 for additional cable installation instructions for EAS equipped Genesis models.
 - Plugging the imager into a port on the host system does not guarantee that scanned information will be communicated properly to the host system. The imager is shipped from the factory configured with default settings. Please refer to the MetroSelect Single-Line Configuration Guide (PN 00-02544) or MetroSet2's help files for instructions on changing the imager's configuration. In addition, please check that the imager and host system are using the same communication protocol.
- ♦ The MS7580 requires 12V power to function for RS232 operation. Honeywell recommends using the external power supply shipped with the MS7580.

Keyboard Wedge

1. Turn off power to the host device.
2. Plug the interface cable's modular connector into the socket on the imager.
3. Disconnect the keyboard from the host device.
4. Connect the "Y" ends of the communication cable to the keyboard and the keyboard port on the host device. A male/female adapter cable is supplied with the imager kit.
5. Plug the 12V power supply♦ into the power jack on the cable.
6. Check the AC input requirements of the power supply to verify the voltage matches the AC outlet. The outlet must be located near the equipment and be easily accessible.
7. Connect AC power to the transformer.
8. The MS7580 will start to initialize. The white and blue LED will alternately fade on and off for three seconds. When the imager has finished initializing, the imager will flash the white LED three times while simultaneously beeping three times. The low intensity blue LED will remain turned on.
9. Turn on power to the host device.

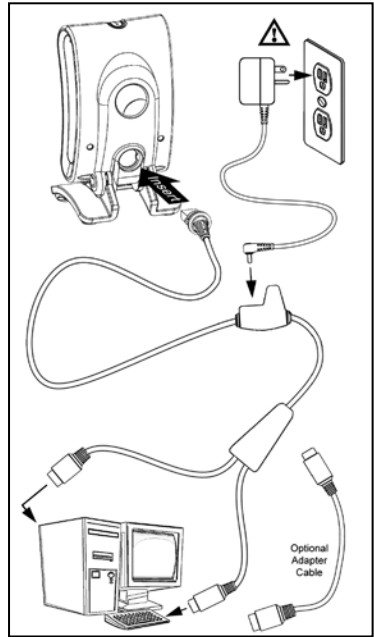

Figure 6. Keyboard Wedge

 See caution on page 5.

Installation Note

Plugging the imager into a port on the host system does not guarantee that scanned information will be communicated properly to the host system. The imager is shipped from the factory configured with default settings. Please refer to the MetroSelect Single-Line Configuration Guide (PN 00-02544) or MetroSet2's help files for instructions on changing the imager's configuration. In addition, please check that the imager and host system are using the same communication protocol.

♦ The MS7580 requires 12V power to function for Keyboard Wedge operation.

RS485

1. Turn off power to the host device.
2. Plug the interface cable's modular connector into the socket on the imager.
3. Connect the other end of the cable to proper COM port of the host device ♦.
4. Turn on power to the host device.
5. The MS7580 will start to initialize. The white and blue LED will alternately fade on and off for three seconds. When the imager has finished initializing, the imager will flash the white LED three times while simultaneously beeping three times. The low intensity blue LED will remain turned on.

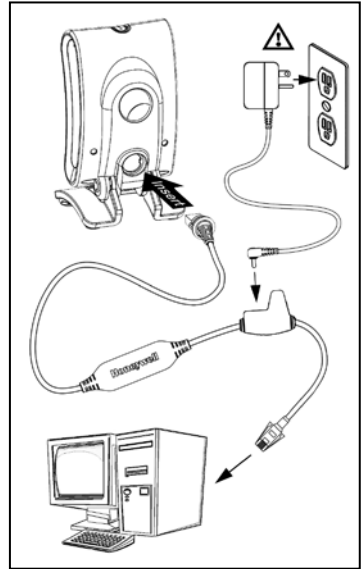

Figure 7. RS485

Installation Note

Plugging the imager into a port on the host system does not guarantee that scanned information will be communicated properly to the host system. The imager is shipped from the factory configured with default settings. Please refer to the MetroSelect Single-Line Configuration Guide (PN 00-02544) or MetroSet2's help files for instructions on changing the imager's configuration. In addition, please check that the imager and host system are using the same communication protocol.

- ♦ The MS7580 requires 12V power from the host for RS485 operation.

USB

1. Turn off power to the host device.
2. Plug the interface cable's modular connector into the socket on the imager.
3. Plug the USB end of the cable into the host's USB port.

Steps 4–6 are for VLink cables with a built in power jack and 12V external power supply. Skip to step 6 for USB direct connect cables♦ receiving 12V power from the host.

4. Plug the power supply into the power jack on the VLink cable.
5. Check the AC input requirements of the power supply to verify the voltage matches the AC outlet. The outlet must be located near the equipment and be easily accessible.
6. Connect AC power to the transformer.
7. Turn on power to the host device.
8. The MS7580 will start to initialize. The white and blue LED will alternately fade on and off for three seconds. When the imager has finished initializing, the imager will flash the white LED three times while simultaneously beeping three times. The low intensity blue LED will remain turned on.

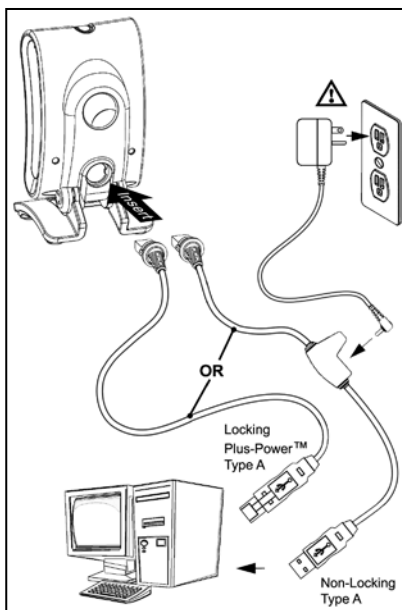

Figure 8. USB

 See caution on page 5.

Installation Notes

- MS7580-124-EAS models are equipped with an integrated RF EAS antenna. See page 39 for additional installation instructions for MS7580-124-EAS models.
 - The MS7580 meets the requirements for Full Speed USB hardware. The USB interface is configurable for Keyboard Emulation Mode, Bi-Directional Serial Emulation Mode or IBM OEM. The default setting for the USB interface is Keyboard Emulation Mode.
- ♦ *The MS7580 requires 12V power from the host for pass-through capabilities to function. See page 3 for a complete list of USB cable options.*

-
- For information on configuring the MS7580 for USB Serial Emulation Mode or IBM OEM, refer to the USB section of the MetroSelect Single-Line Configuration Guide (PN 00-02544).
 - Plugging the imager into a port on the host device does not guarantee that scanned information will be communicated properly to the host device. The imager is shipped from the factory configured with default settings. Please refer to the MetroSelect Single-Line Configuration Guide (PN 00-02544) or MetroSet2's help files for instructions on changing the imager's configuration. In addition, please check that the imager and host system are using the same communication protocol.

Mounting the MS7580

Components of Adapter Kit 46-00911

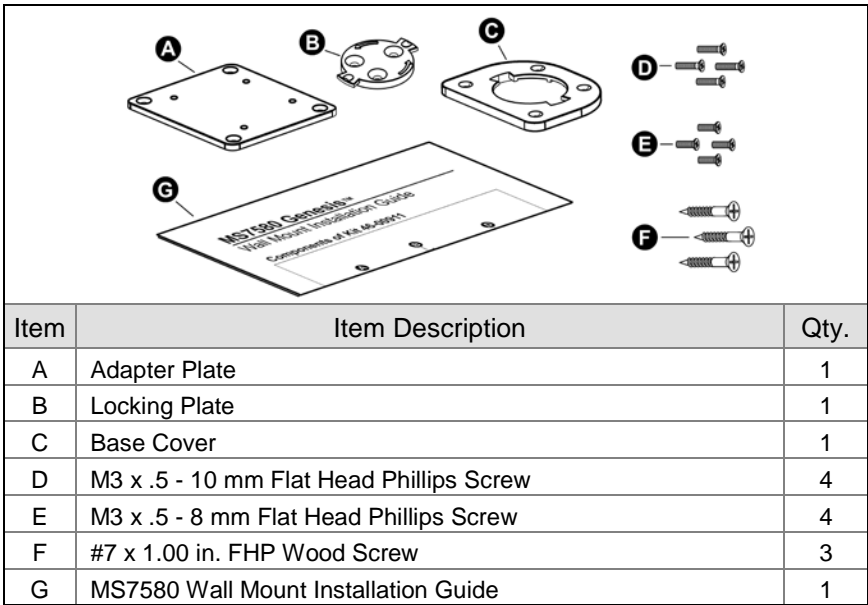

Figure 9. 46-00911 Kit Components

Components of Wall Mount Kit 46-00913

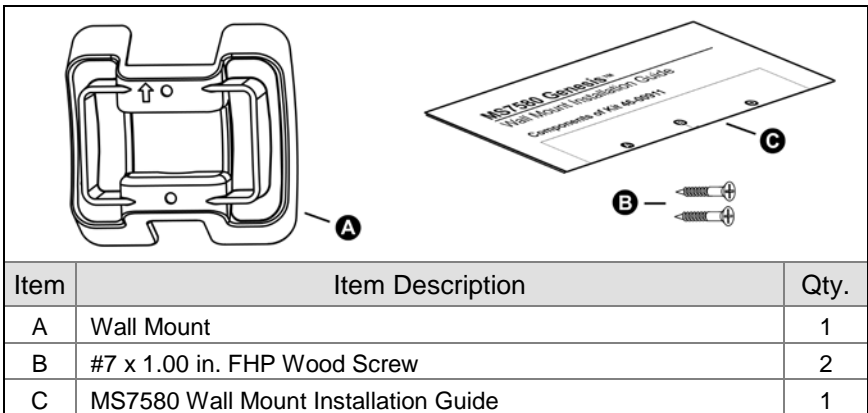

Figure 10. 46-00913 Kit Components

Installation of Adapter Kit 46-00911

1. Remove the rubber feet on the bottom of the MS7580.
2. Attach the adapter plate to the bottom of the imager with the four M3 x .5 x 10 mm screws (■) provided in the kit.
3. Attach the base plate to the adapter plate with the four M3 x .5 x 8 mm screws (●) provided in the kit.

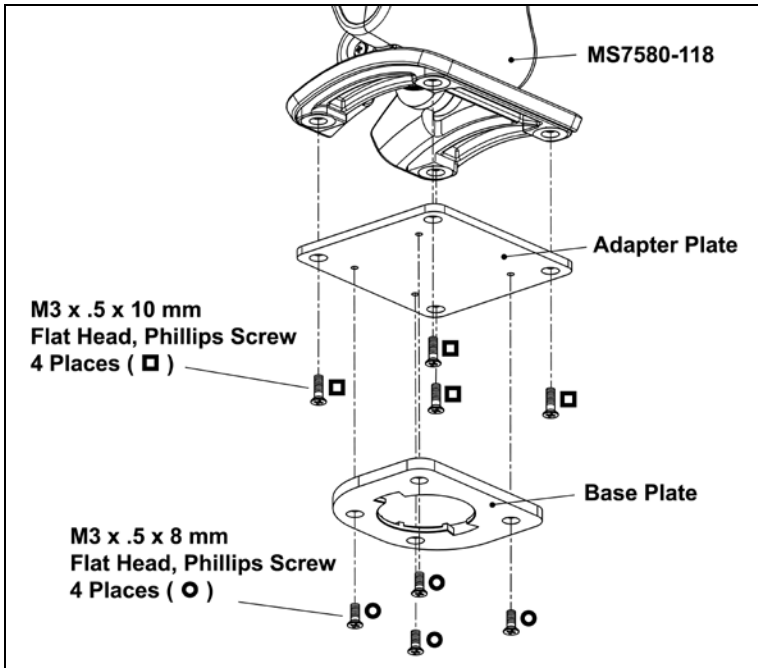

Figure 11

4. Before mounting the locking plate, consider the position the imager will rest when fully installed. There are two tabs located on the locking plate. These tabs indicate the two directions the imager may face when locked into position (see figure below).

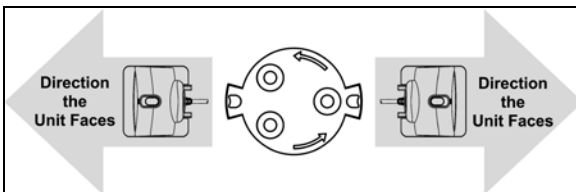

Figure 12

-
- Use the locking plate as a guide to drill three #39 pilot holes (A) in the mounting surface.

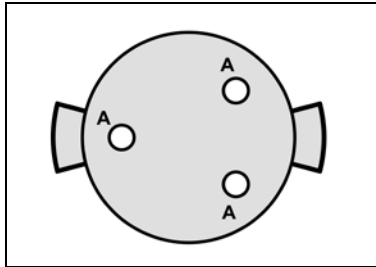

Figure 13. Locking Plate (Not Drawn to Scale)

- Secure the locking plate to the wall with the three #7 wood screws (◆) provided in the kit.

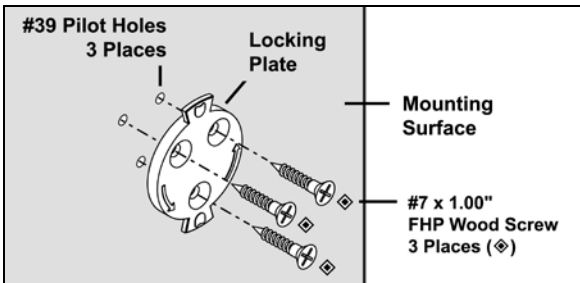

Figure 14

- Position the imager so the base plate sits flush over the locking plate. Twist the imager 90° counter-clockwise to lock the imager into place.

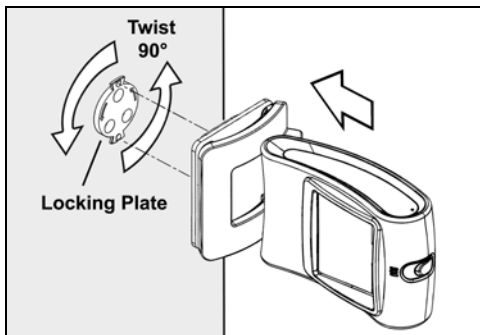
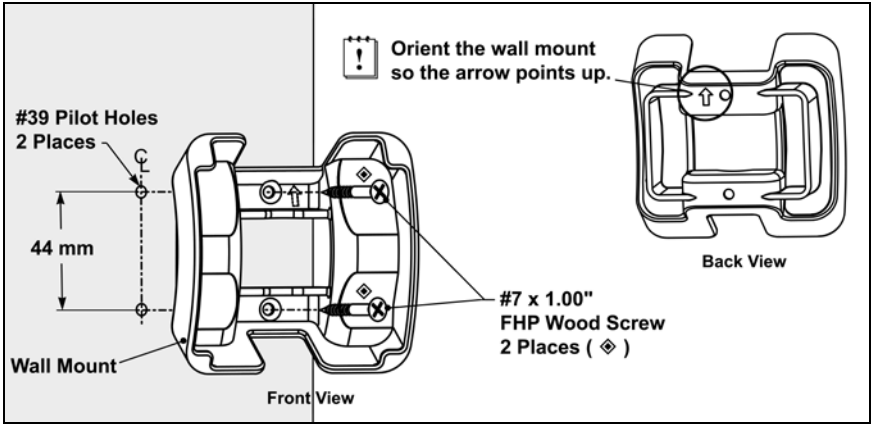

Figure 15

Installation of Wall Mount Kit 46-00913

1. Drill two #39 pilot holes in the mounting surface. The pilot holes should be centered vertically 44 mm apart.
2. Position the wall mount over the pilot holes with the arrow pointing up.
3. Secure the wall mount to the wall with the two #7 wood screws (◆) provided in the kit.



4. Slide the imager's base under the upper corner tabs on the wall mount.
5. Slide the remainder of the base in and down behind the lower corner tabs.

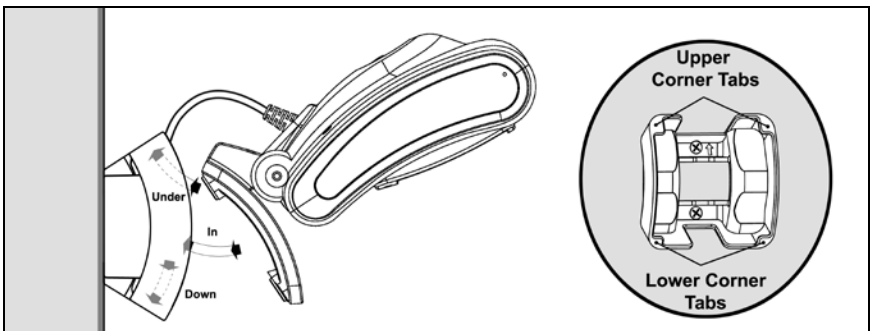

Operation

Modes of Operation

The MS7580 supports two standard modes of operation for scanning bar codes, automatic activation and manual activation scanning. Scanning while in the automatic activation mode can occur in either one of two configurable options, pass-through[◆] or presentation. Both the pass-through and the presentation options are enabled by default.◆◆ With the default configuration, the imager operates in the pass-through state for 300 ms and then changes to the presentation state for additional decoding capability.

Automatic Activation Mode

Pass-through Scanning[◆]—The imager decodes only 1D and PDF bar codes.

Scanning method:

1. Pass the bar code through the active scan area to scan, decode and send data.

Presentation Scanning—The imager decodes all 1D, PDF and 2D matrix codes

Scanning method:

1. Place the object in the IR activation range.
2. Hold the object's bar code in front of the scan window within the active scan area to scan, decode and send data.

Manual Activation[◆]

The imager decodes all 1D, PDF and 2D matrix codes.

Scanning method:

1. Press the button one time to activate linear targeting.
2. Press the button one time to activate linear targeting.

◆ *The MS7580 requires 12V power for pass-through capabilities to function.*

◆◆ *The default configuration is recommended for optimum scan performance.*

◇ *Imager configuration bar codes require the manual activation mode.*

-
3. Press the button one time to activate linear targeting.
 4. Align the linear targeting line over the desired bar code.

Note: When scanning 1D bar codes, the bar code must be presented to the imager in the correct orientation, see *Figure 18*. PDF and 2D matrix codes may be presented in any orientation.



Figure 18. 1D Bar Code Orientation

5. Press button a second time to decode and send the data
6. The imager will return to the default presentation mode by either the default time length or by double pressing the button.

Note: Decoding and functional capability of the imager is restricted through the use of license numbers provided by Honeywell. Imagers will not support key features such as, but not limited to, the ability to decode PDF, 2D or OCR fonts without proper licenses. If you wish to purchase a limited license for one or more of the key features not included in the standard imager, please specify at the time of sale or otherwise contact a customer service representative for more information. Standard models ship with the ability to read all 1D, PDF, and 2D bar codes. OCR fonts are disabled by default and must be specifically requested at an additional cost.

Audible Indicators

The MS7580 provides audible feedback during operation. The audible feedback indicates the status of the imager. Eight settings are available for the tone of the beep (normal, 6 alternate tones and no tone). To change the tone, refer to the MetroSelect Single-Line Configuration Guide, PN 00-02544 or MetroSet2's help files.

One Beep

When the imager successfully reads a bar code the imager will beep once and the white LED will flash once indicating data has been transmitted successfully. The blue LED will return to the low intensity state if no other objects are presented in the active scan area.

If the imager does not beep once and the white light does not flash, then the bar code has not been successfully read.

Short Razzberry Tone

This tone is a failure indicator (see Failure Modes on page 21).

Long Razzberry Tone

This tone is a failure indicator (see Failure Modes on page 21).

Three Beeps - At Power Up

When the MS7580 first receives power it will start an initialization sequence. The white and blue LEDs will alternately fade on and off for approximately 3 seconds. When the imager has finished initializing the white LED will flash three times while simultaneously beeping three times to indicate the imager is ready for use.

Three Beeps - Configuration Mode

When entering configuration mode, the white LED will flash while the imager simultaneously beeps three times. The white and blue LEDs will continue to flash while in this mode. Upon exiting configuration mode, the imager will beep three times, and the LEDs will stop flashing.

When configured, 3 beeps can also indicate a communications timeout during normal scanning mode.

When using single-code-configuring, the imager will beep three times: a normal tone followed by a short pause, a high tone and then a low tone. This indicates that the single configuration bar code has successfully configured the imager.

Visual Indicators

The imager has blue and white LED indicators surrounding the button on the top of the imager. When the imager is on, the intensity of the LED and the flashing or stationary activity of the LEDs, indicates the status of the current scan and the diagnostic imager.

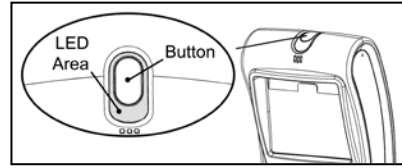

Figure 19.

No LEDs are Illuminated

The LEDs will not be illuminated if the imager is not receiving power from the host or transformer.

Steady Low Intensity Blue

The imager is in stand-by mode. Present a bar code to the imager and the blue LED will switch to a high intensity blue when the IR detects the object.

Steady High Intensity Blue

The high intensity blue LED is illuminated when the imager is active and attempting to decode a barcode.

Single White Flash

When the imager *successfully* reads a bar code the imager will beep once and the white LED will flash once indicating data has been transmitted successfully. The blue LED will return to the low intensity state if no other objects are presented in the active scan area.

If the imager does not beep once and the white light does not flash, then the bar code has *not* been successfully read.

Steady White

When the imager successfully reads a bar code it will beep once and the white LED will turn on indicating data is being transmitted.

Note: After a successful scan, the imager transmits the data to the host device. Some communication modes require that the host inform the imager when data is ready to be received. If the host is not ready to accept the information, the imager's white LED will remain on until the data can be transmitted.

Alternating Flashing of Blue and White

This indicates the imager is in configuration mode. A short razzberry tone indicates that an invalid bar code has been scanned while in this mode.

Failure Modes

Long Razzberry Tone – During Power Up

Failed to initialize or configure the imager. If the imager does not respond after reconfiguration, return the imager for repair.

Short Razzberry Tone – During Scanning

An Invalid bar code has been scanned when in configuration mode.

Field of View

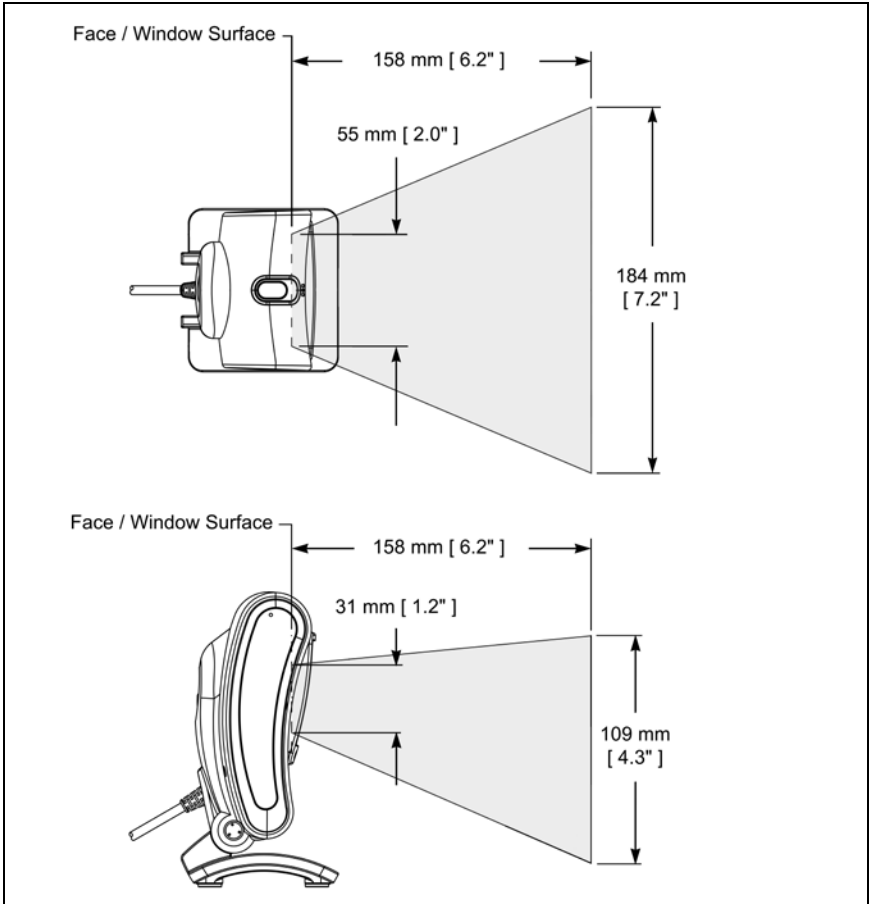

Figure 20. Field of View

Depth of Field by Minimum Bar Code Element Width

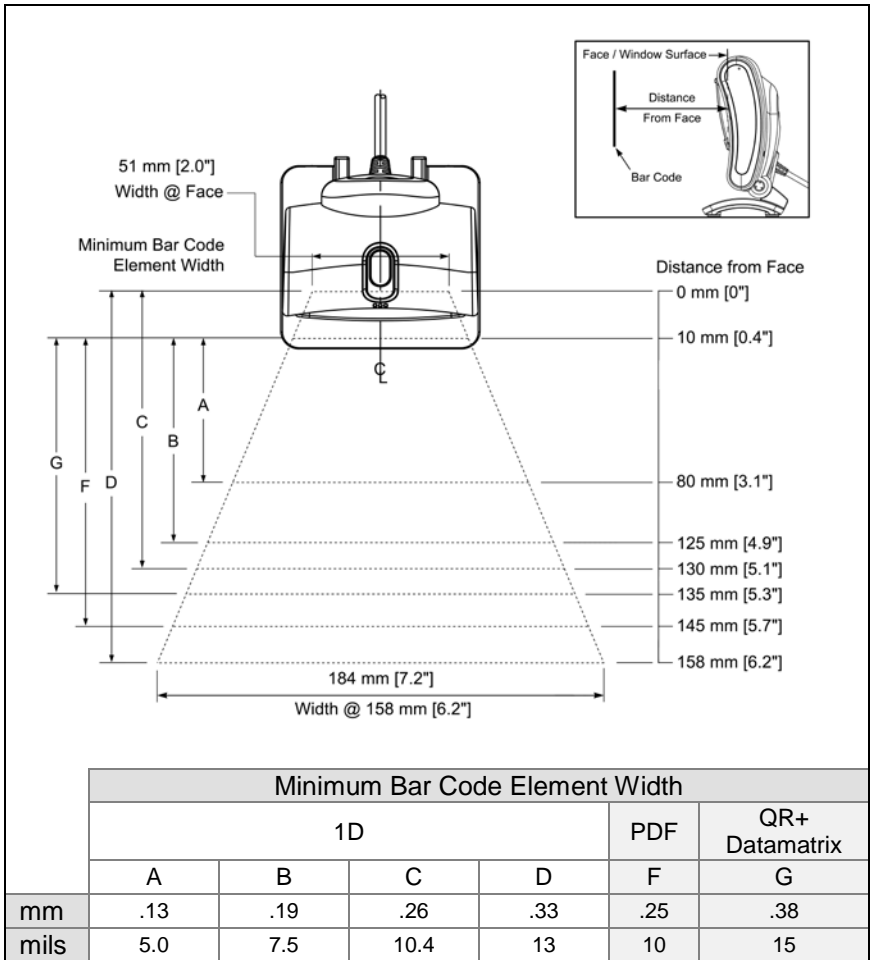

Figure 21. Depth of Field by Minimum Bar Code Element Width

Note: Standard models ship with the ability to read all 1D, PDF and 2D bar codes. Decoding and functional capability is limited and imagers will not support key features including, but not limited to, the ability to decode PDF, 2D or OCR fonts without proper limited use licenses provided by Honeywell. If you wish to purchase a limited license for one or more of the key features not included in the standard imager, please specify at the time of sale or otherwise contact a customer service representative for more information.

IR Activation Range

The MS7580 has a built in object detection sensor that instantly turns on the imager when an object is presented within the imager's IR Activation Area, shown below.

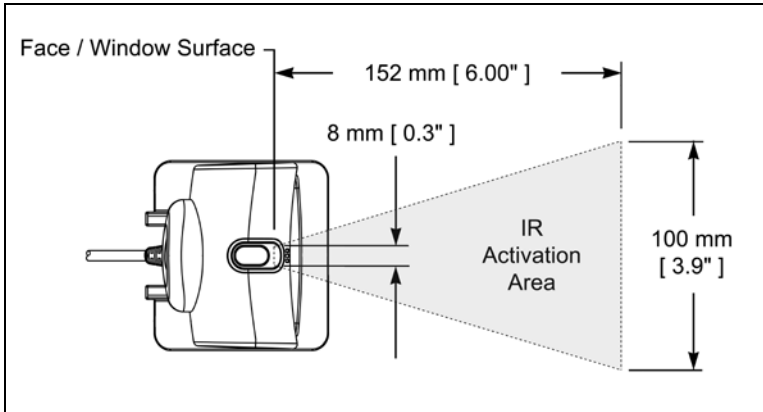

Figure 22. IR Activation Area

Illumination Source

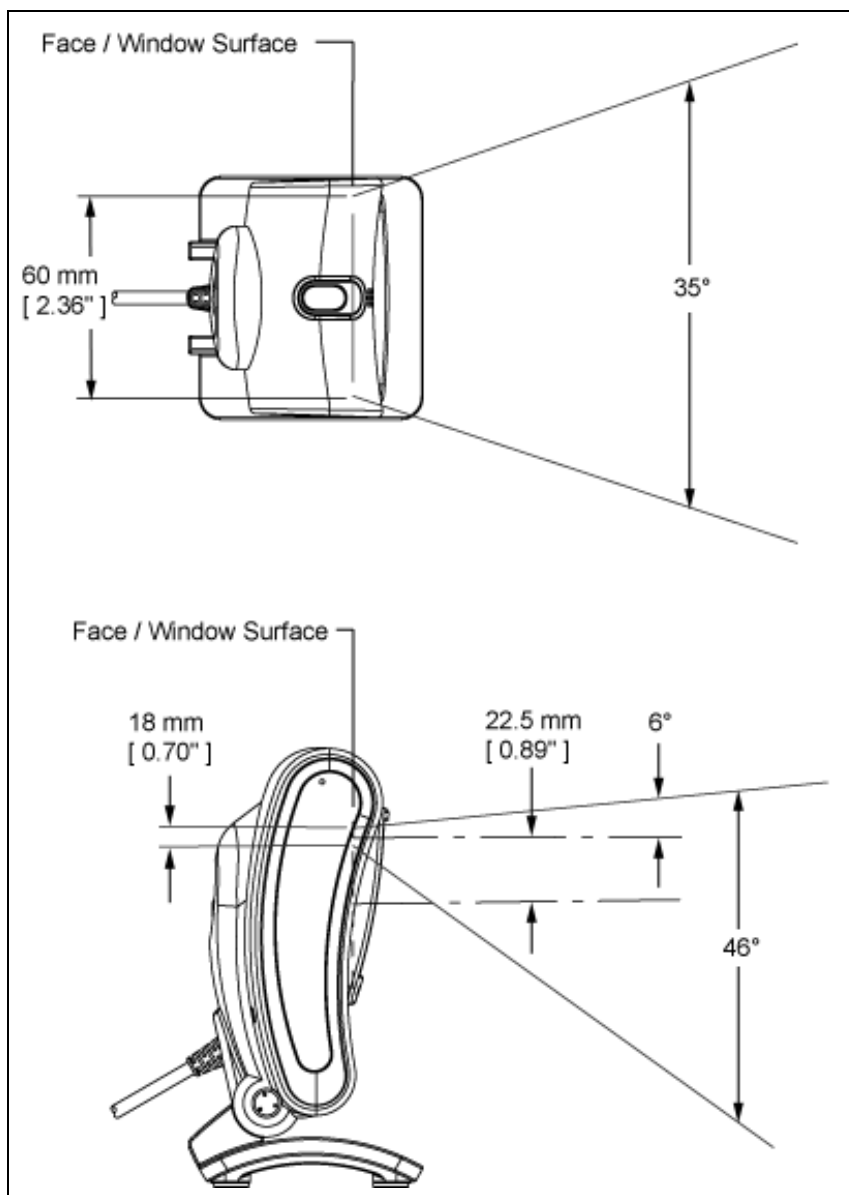

Figure 23. Illumination Source

IR Source

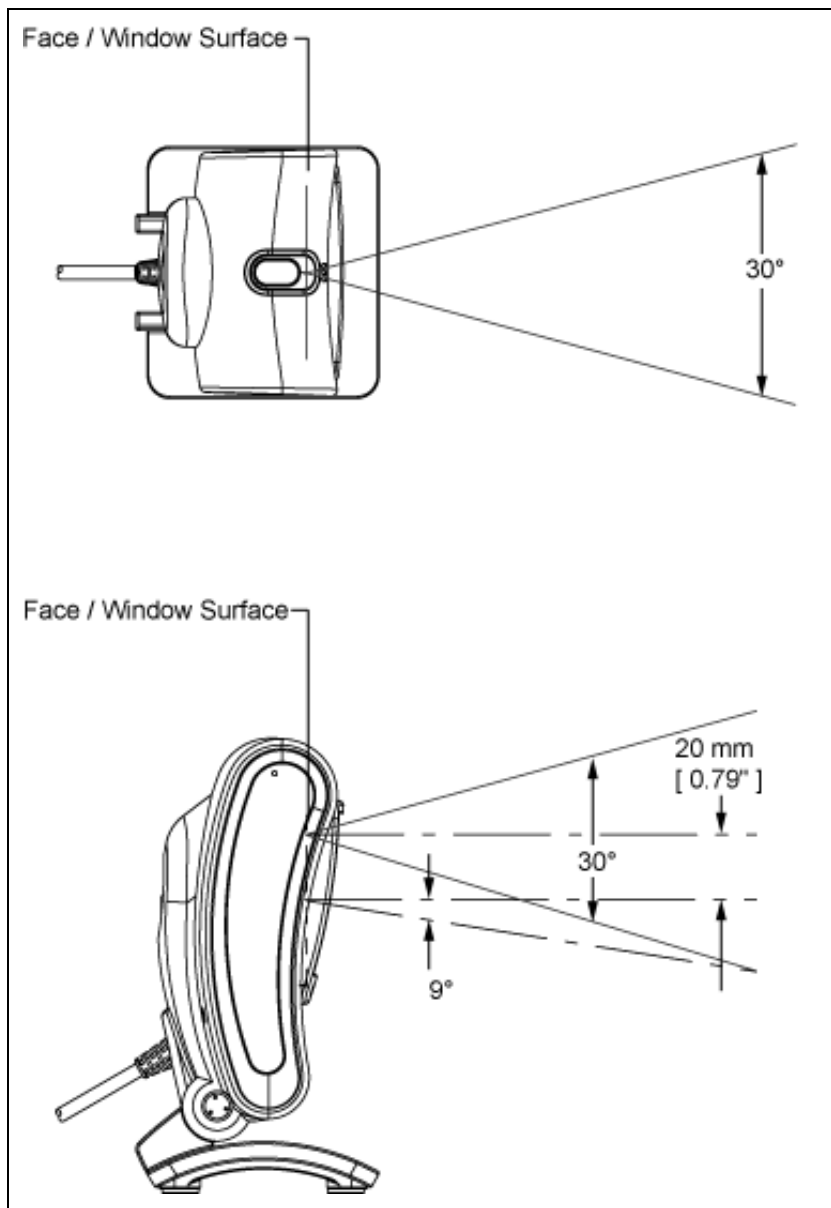

Figure 24. IR Source

Targeting Source

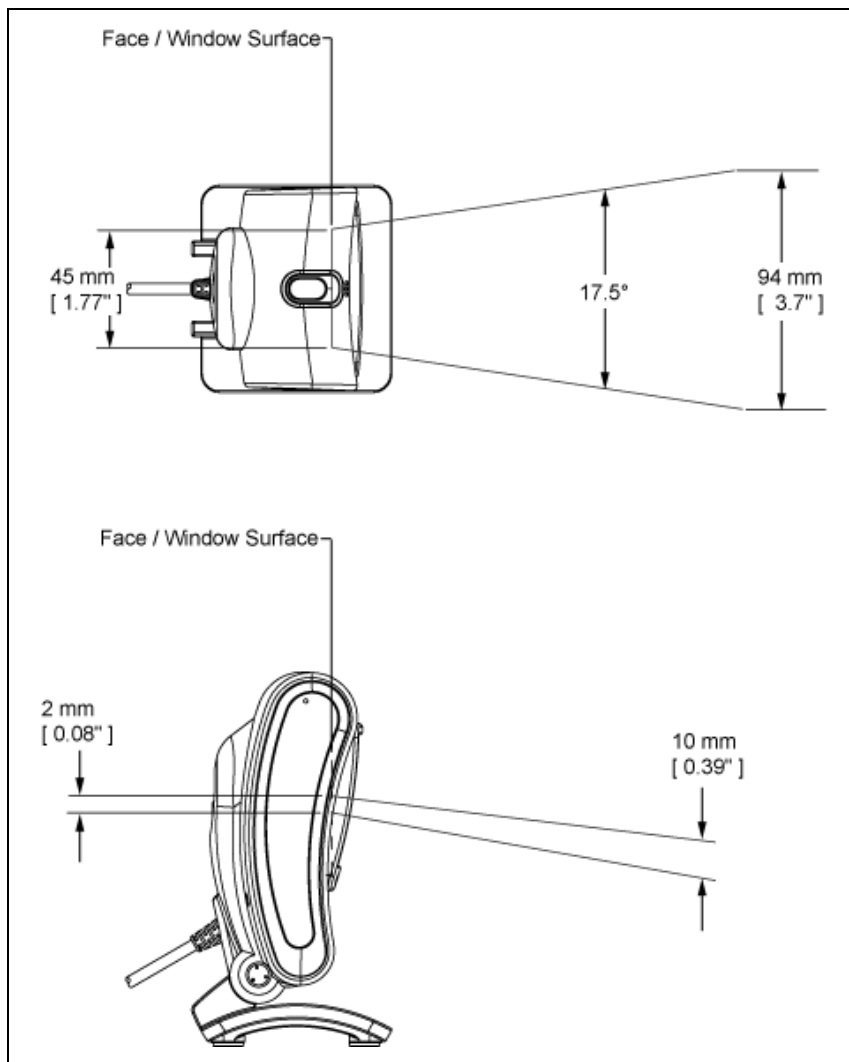

Figure 25. Targeting Source

Troubleshooting Guide

The following troubleshooting guide is for reference purposes only. Contact a customer service representative or technical support representative to preserve the limited warranty terms. See page 61 for contact information.

All Interfaces

Symptoms	Possible Causes	Solution
No LEDs, beep or illumination	No power is being supplied to the imager.	Check transformer, outlet, and power strip. Make sure the cable is plugged into the imager.
	No power is being supplied to the imager from the host.	Some host systems cannot supply enough current to power the MS7580. A power supply may be required.
Long Razz tone on power up	There has been a imager configuration failure.	Contact a customer service representative, if the imager will not hold the saved configuration.
	There has been a diagnostic failure.	Contact a customer service representative, if the imager will not function.
Long Razz tone when exiting configuration mode	There was a failure saving the new configuration.	Re-try to configure the imager. Contact a customer service representative if the imager will not hold the saved configuration.
Long Razz tone	There is a scanning mechanism failure.	Contact a customer service representative.
Short Razz tone in configuration mode	An invalid bar code has been scanned.	Scan a valid bar code or quit configuration mode.

Symptoms	Possible Causes	Solution
The imager powers up, but does not beep when bar code is scanned.	The beeper is disabled and no tone is selected.	Enable the beeper and select a tone.
The imager powers up, but does not scan and/or beep.	The bar code symbology trying to be scanned is not enabled.	UPC/EAN, Code 39, interleaved 2 of 5, Code 93, Code 128, Codabar and PDF are enabled by default. Verify that the type of bar code being read has been selected.
The imager powers up, but does not scan and/or beep.	The imager is trying to scan a barcode that does not match the configured criteria.	Verify that the bar code being scanned falls into the configured criteria (i.e. character length lock or minimum bar code length settings).
The following item is only relevant for RS232 and Serial USB Interfaces.		
The imager scans a bar code, but locks up after the first scan and the white LED stays on.	The imager is configured to support some form of host handshaking but is not receiving the signal.	If the imager is setup to support ACK/NAK, RTS/CTS, or XON/XOFF, verify that the host cable and host are supporting the handshaking properly.
The imager scans, but the data transmitted to the host is incorrect.	The imager's data format does not match the host system requirements.	Verify that the imager's data format matches that required by the host. Make sure that the imager is connected to the proper host port.

Symptoms	Possible Causes	Solution
The imager beeps at some bar codes and NOT for others of the same bar code symbology.	The bar code may have been printed incorrectly.	Check if it is a check digit/character/or border problem.
	The imager is not configured correctly for this type of bar code.	Check if check digits are set properly.
	The minimum symbol length setting does not work with the bar code.	Check if the correct minimum symbol length is set.
The imager scans the bar code but there is no data.	The configuration is not set correctly.	Make sure the imager is configured for the appropriate mode.
The next four items are only relevant for a Keyboard Wedge interface.		
The imager scans but the data is not correct.	The configuration is not set correctly.	Make sure that the proper PC type AT, or PS2 is selected. Verify correct country code and data formatting are selected. Adjust inter-character delay symptom.
The imager is transmitting each character twice.	The configuration is not set correctly.	Increase interscan code delay setting. Adjust whether the F0 break is transmitted. It may be necessary to try this in both settings.
Alpha characters show as lower case.	The computer is in Caps Lock mode.	Enable Caps Lock detect setting of the imager to detect if the PC is operating in Caps Lock.
Everything works except for a couple of characters.	These characters may not be supported by that country's key look up table.	Try operating the imager in Alt mode.

Symptoms	Possible Causes	Solution
The imager scans but the data is not correct.	The imager and host may not be configured for the same interface parameters.	Check that the imager and the host are configured for the same interface parameters.
The following item is only relevant for an RS232 interface.		
The imager powers up OK and scans OK but does not communicate properly with the host.	The com port at the host is not working or not configured properly.	Check to make sure that the baud rate and parity of the imager and the communication port match and the program is looking for "RS232" data.
The imager powers up OK and scans OK but does not communicate properly with the host.	The cable is not connected to the correct com port.	Check to make sure that the cable is connected to the correct com port.
Characters are being dropped.	Inter-character delay needs to be added to the transmitted output.	Add some inter-character delay to the transmitted output by using the Configuration Guides (PN 00-02544 and 00-05252).
The following item is only relevant for a USB interface.		
No LEDs, beep or Illumination	The USB host may not be active. The MS7580 will not operate from hub/host power without host communication.	Turn on the host device.
	The imager is not receiving sufficient power to support operation. <i>Refer to the electrical specifications on page 34.</i>	Verify adequate power is being supplied to the imager.

Design Specifications

Operational

Light Source:	LED 645 nm \pm 7.5 nm	
Pulse Duration:	Up to 600 μ s (Default)	
Maximum Output of the LED:	Maximum 70 mA emits 5800 mlm	
Depth of Scan Field:	0 mm – 158 mm (0" – 6.2") for 0.33 mm (13 mil)	
Field of View:	51 mm x 31 mm (2.0" x 1.2") @ Face / Window	
	184 mm x 109 mm (7.2" x 4.3") @ 158 mm (6.2") from Face	
Minimum Element Width:	1D	0.1 mm (4 mil)
	2D	0.254 mm (10 mil)
Resolution:	832 x 504 Pixels	
Infrared Activation Range:	0 mm (0") face to 152 mm (6")	
Optional Decode and Imaging Capabilities:	Autodiscriminates all Standard 1-D, RSS, PDF417, microPDF, MaxiCode, Data Matrix, QR Code, UCC, EAN Composites, Postals, Aztec (<i>Image Transfer</i>) – BMP, TIFF, or JPEG output on USB and RS232 Interfaces	
System Interfaces:	PC Keyboard Wedge, RS232, USB, RS485 (external via cable)	
Print Contrast:	20% Minimum Reflectance Difference	
Number Characters Read:	4096 Bytes Maximum	
Beeper Operation:	7 tones or no beep	
Indicators (LED) <i>Default Settings:</i>	High Intensity Blue	The imager is active and attempting to scan.
	Low Intensity Blue	The imager is idle.
	White	Good Read

Mechanical

Height (H):	150 mm (5.91")	
Width (W):	83 mm (3.27")	
Depth (D):	80 mm (3.15")	
Weight:	340 g ± 15 g (12 oz. ± 5 oz.)	
Termination:	10 pin modular RJ45	

Electrical

		+12 Volt Adapter Value	+5 Volt USB Power Value
Input Voltage:		12VDC ± 0.25V	5VDC ± 0.25V
Power:	Peak ♦	2.0 W (Typical)	1.6 W (Typical)
	Operating	1.7 W (Typical)	1.4 W (Typical)
	Idle	1.3 W (Typical)	1.0 W (Typical)
Current:	Peak ♦	167 mA (Typical)	320 mA (Typical)
	Operation	142 mA (Typical)	280 mA (Typical)
	Idle	109 mA (Typical)	200 mA (Typical)
		♦ Peak Values of at least 1 ms in width.	
DC Transformer:	Class 2; 12VDC @ 1.25 A		
<i>For regulatory compliance information see pages 55–58</i>			

Environmental

Temperature:	Operating = 0°C to 40° (32° to 104°F)
	Storage = -40°C to 60°C (-40°F to 140°F)
Humidity:	0% to 95% Relative Humidity, Non-Condensing
Light Levels:	Up to 100,000 Lux
Shock:	Designed to withstand 1.5 m (5 ft.) drops
Contaminants:	Sealed to resist airborne particulate contaminants
Ventilation:	None required

Applications and Protocols

The model number on each imager includes the imager number and factory default communications protocol.

Imager	Version Identifier	Communication Protocol(s)
MS7580	124	Interfaces supported include: <ul style="list-style-type: none"> • RS232 (TXD[♦], RXD, RTS[♦], CTS) • USB^{♦♦} • Keyboard Wedge • RS485 (External via Cable)
♦ TXD and RTS are transmitted at TTL levels. Contact a customer service representative for information on additional RS232 options. ♦♦ USB is configurable for Keyboard Emulation Mode, Bi-Directional Serial Emulation Mode or IBM OEM. The default USB setting is Keyboard Emulation Mode.		

The MS7580 with a built-in PC Keyboard Wedge interface is designed for Keyboard emulation use only. Many RS232 configurable functions, available in other Honeywell imagers, are also available as keyboard wedge functions.

The following are the most important selectable options specific to the keyboard wedge.

Keyboard Type

- *AT (includes IBM® PS2 models 50, 55, 60, 80)
- IBM PS2 (includes models 30, 70, 8556)

Keyboard Country Type

- | | | |
|-------------|--------------------|-------------------|
| • *USA | • Italian | • Swiss |
| • Belgian | • Japanese | • Swedish/Finnish |
| • French | • Russian Cyrillic | • Turkish |
| • German | • Slovenian | • United Kingdom |
| • Hungarian | • Spanish | |

* Indicates a default setting. For information on how to change the default settings, refer to the help files in MetroSet2, the MetroSelect Single-Line Configuration Guide or the Area-Imaging Supplemental Configuration Guide.

Configuration and Upgrades

Configuration Modes

The MS7580 has three modes of configuration.

- **Bar Codes**

The MS7580 can be configured by scanning the bar codes included in the MetroSelect Single-Line Configuration Guide or the Area-Imaging Supplemental Configuration Guide. The manuals are available for download at www.honeywellaidc.com.

- **MetroSet2**

This user-friendly Windows®-based configuration program allows you to simply 'point-and-click' at the desired imager options. MetroSet2 is available for download at www.honeywellaidc.com.

- **Serial Programming**

This mode of configuration is ideal for OEM applications. Serial programming mode gives the end-user the ability to send a series of commands using the serial port of the host system. The commands are equivalent to the numerical values of the bar codes located in the MetroSelect Single-Line Configuration Guide.

Upgrading the Firmware

The MS7580 is part of Honeywell's line of imagers with flash upgradeable firmware. The upgrade process requires, a new firmware file supplied to the customer by a customer service representative♦ and Honeywell's MetroSet2 software♦♦. A personal computer running Windows® 95 or greater with an available RS232 serial or USB port is required to complete the upgrade.

Note: Do not use the standard cable supplied with Keyboard Wedge or RS485 MS7580 interface kits for firmware upgrades. If using USB or RS232 for the upgrade process, the standard USB or RS232 cable provided with the imager can be used.

♦ See Contact Information on page 61.

♦♦ MetroSet2 is available for download, at no additional cost, from www.honeywellaidc.com.

To upgrade the firmware in the MS7580:

1. Plug the imager into a serial communication port on the host system.
2. Start the MetroSet2 software.
3. Click on the plus sign (+) next to *POS Scanners* to expand the supported imager list.
4. Choose the MS7580 Genesis from the list.
5. Click on the C*onfigure Genesis/7580 Scanner* button.
6. Choose *Flash Utility* from the options list located on the left side of the screen.
7. Click on the *Open File* button in the Flash Utility window.
8. Locate and open the flash upgrade file.
9. Select the COM port that the imager is connected to on the host system.
10. Verify the settings listed in the Flash Utility window.
11. Click on the *Flash Imager* button to begin the flash upgrade. A message will appear on the screen when the upgrade is complete.

MS7580-124-EAS Model

MS7580-124-EAS models are equipped with an integrated antenna for Electronic Article Surveillance (EAS) system support. The following information should be used in conjunction with the manufacturer's EAS system documentation for successful integration of an MS7580-124-EAS Genesis.

Integrated RF EAS Antenna Connection

The following information is applicable for MS7580-124-EAS kits containing an RS232, MX-5S114-E-3 cable or a USB, MX-5S236-E-3 cable.

Insert the cable's EAS connector into the antenna connector on the imager. There will be an audible click when the connector lock engages.

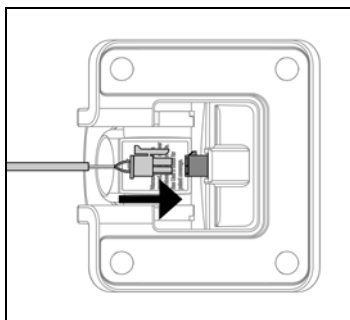

Figure 26. Antenna Connect

EAS System Connection

The following information should be used in conjunction with the manufacturer's documentation EAS system.

Checkpoint® EAS System Integration

Honeywell cables compatible with Checkpoint EAS systems include five additional wires for device connection*. Consult the table below for the appropriate wire and terminal configuration.

Antenna and Interlock [†] Connection			
Cable (MX-5S236-E-3 or MX-5S114-E-3)		Checkpoint Device	
Wire Color	Wire Gauge	Connection	Type
Solid Light Green	Thin	INTLK + Terminal	Interlock [†]
Solid Black	Thin	INTLK - Terminal, GND	
Red and White	Thick	Antenna + Terminal	Antenna
Black and White	Thick	Antenna - Terminal	
No Insulation/Shield		Antenna Shield	

[†] Interlock functionality requires specific EAS device settings. Consult the manufacturer's EAS system documentation for the appropriate switch and timing potentiometer settings.

* Caution Statements

For North America:

Caution: To maintain compliance with applicable standards, all circuits connected to the scanner must meet the requirements of a NEC Class 2 power source or Limited Power Source as defined in UL 60950-1 2nd edition Clause 2.5.

For Other Countries:

Caution: To maintain compliance with applicable standards, all circuits connected to the scanner must meet the requirements of a Limited Power Source as defined in IEC 60950-1 2nd edition Clause 2.5.

Inside the Checkpoint device, two switch banks set the deactivation antenna tuning. The recommended settings for the switch banks are shown below. See page 44 for tag deactivation guidelines.

Switch Bank Settings			
SW1		SW2	
Switches 1 - 6	OFF	Switches 1 - 6	OFF

Settings of 0pF to 47pF are recommended to achieve a maximum deactivation range.

Configuration for EAS Applications

EAS support is disabled by default in the MS7580-124-EAS series. To enable EAS support the imager must be configured for a system type and signal mode. Follow the configuration sequence below to configure the imager for EAS functionality.

1. Scan the system type bar code below to enable EAS system support.

Enable Checkpoint System EAS Support



2. Scan either the *Enable Continuous Mode* bar code **or** the *Enable Regular Mode* bar code.

Regular Mode

In regular EAS mode, the imager will signal the EAS system to activate immediately after the area imager successfully transmits a bar code. The imager will also signal the EAS system to deactivate after the configured EAS timeout expires.

Note: If *regular mode* is enabled an EAS timeout length will need to be configured (see page 43).

Enable Regular Mode



Continuous Mode

In continuous mode, the imager will signal the EAS system to activate when it first powers on. The area imager will never deactivate the EAS system while in continuous mode. The EAS timeout setting has no effect in continuous mode.

Enable Continuous Mode



-
3. Scan the desired EAS timeout length (applicable for *regular mode* only). The EAS timeout length specifies the maximum time that the area imager will leave the EAS interlock signal asserted following a successful scan. The EAS timeout setting has no effect in continuous mode.

Note: If the area imager routinely fails to deactivate EAS tags, increase the value of the timeout setting.

EAS Timeout 100 ms



EAS Timeout 500 ms



EAS Timeout 1s



EAS Timeout 5s



To Disable EAS Support

Scan the bar code below to disable EAS support.

Disable EAS Support



EAS Tag Deactivation Range

Antenna Precaution

The integrated EAS antenna is built into the stand/base of the imager. Do not enclose or rest the imager's base in close proximity to dense metal. The metal may interfere with the antenna decreasing the expected deactivation range.

Tag Storage Precaution

Do not store tags within 45.7 cm [18.0"] of the MS7580. Tags stored closer than 45.7 cm [18.0"] may be unintentionally deactivated. The precautionary area includes storage areas located under the MS7580.

Deactivation Range

Proper tag deactivation requires the entire tag to pass through the expected tag deactivation range indicated in figures 24 (below) and 25 (on page 45).

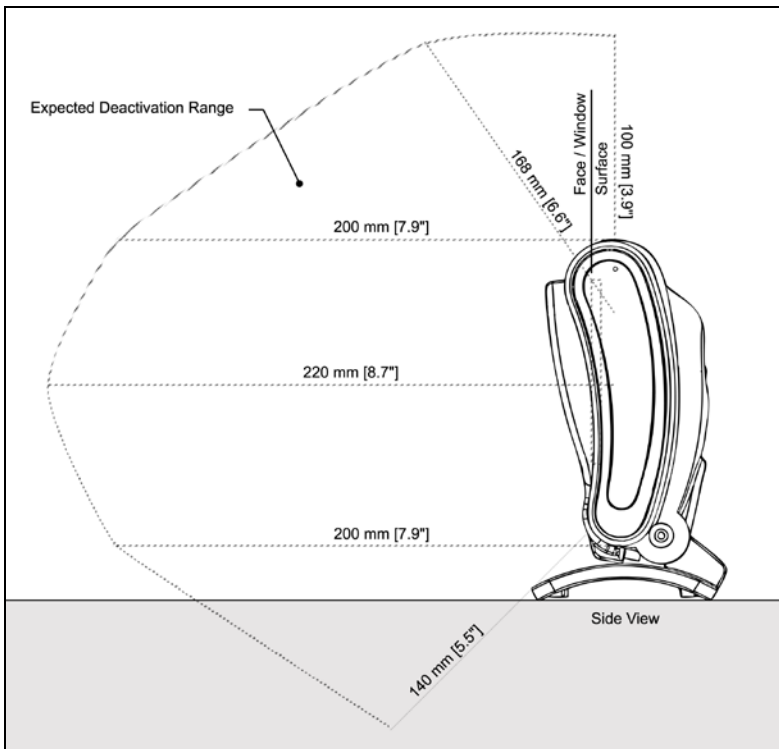

Figure 27. Expected Tag Deactivation Area (Side View)

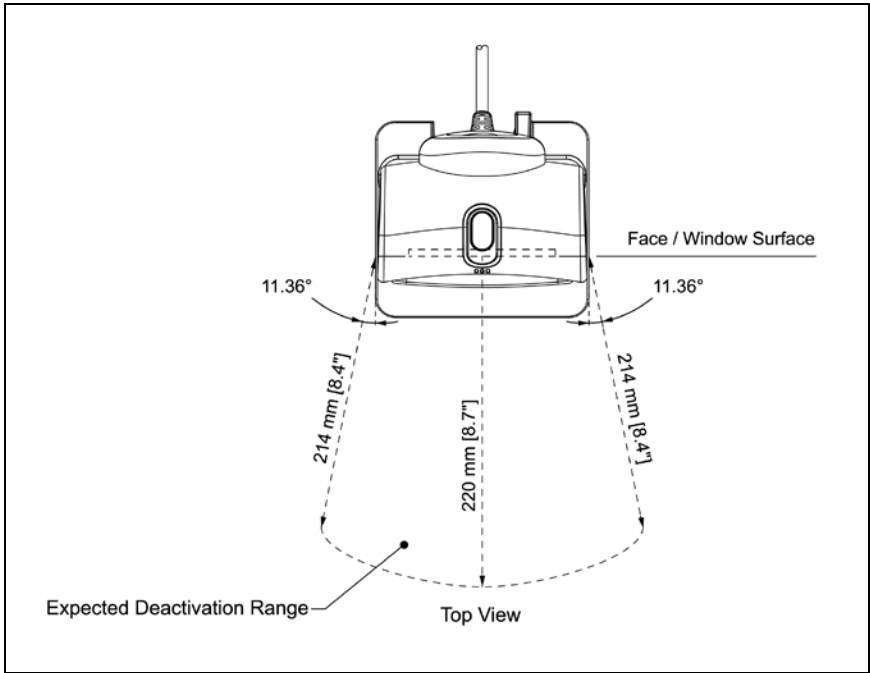

Figure 28. Expected Tag Deactivation Area (Top View)

Imager Pinouts–MS7580-124-EAS

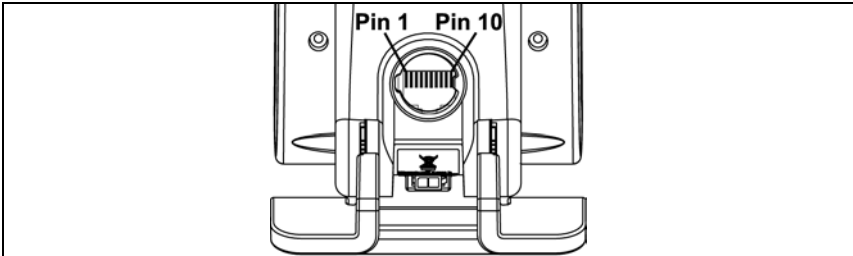

Figure 29. MS7580-124-EAS, 10-Pin Female Modular Socket

RS232		USB♦♦	
Pin	Function	Pin	Function
1	Signal/Power Ground	1	Signal/Power Ground
2	CTS Input	2	Tied to Pin 4 in Cable
3	RS232 Receive Input	3	No Connect
4	No Connect	4	Tied to Pin 2 in Cable
5	Reserved	5	Reserved
6	RTS Output ✧	6	USB D+
7	Reserved	7	+5VDC USB Power
8	RS232 Transmit Output ✧	8	USB D-
9	+12V Power	9	+12V Power
10	Shield Ground	10	Shield Ground
SHELL	Signal/Power Ground	SHELL	Signal/Power Ground



Integrated RF EAS Antenna (MS7580-124-EAS Models Only)	
Pin	Function
1	EAS ANT -
2	EAS ANT +

Figure 30. 2-Pin Box Receptacle

- ♦♦ USB requires 12V power for pass-through functionality.
- ✧ Signals on Pin 6 and 8 are TTL full level RS232 output signals on MS7580-124-EAS models.

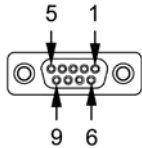
Cable Pinouts (Host End)[‡]

RS232, 12V VLink Cable MX-5S114-E-3		
Pin	Function	 <p>Figure 31. 9-Pin Female, D-Type</p>
1	Shield Ground	
2	RS232 Receive Output	
3	RS232 Transmit Input	
4	DSR	
5	Power/Signal Ground	
6	DTR	
7	RTS	
8	CTS	
9	Host +12VDC	

USB MX-5S236-E-3		
Pin	Function	 <p>Figure 32. USB Type A, Non-Locking</p>
1	PC +5V/V_USB	
2	D-	
3	D+	
4	Ground	

Antenna Disconnect

1. Press the release lock on the cable's EAS connector.
2. Pull the connector free..

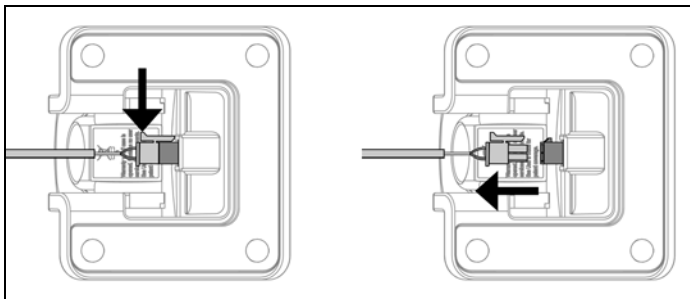

Figure 33. Antenna Disconnect

[‡] MS7580-124-EAS compatible cables. For standard MS7580 cable pinouts refer to page 50.

Imager and Cable Terminations

Standard Imager Pinouts[‡]

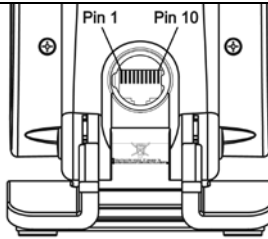

Figure 34. Back/Connector View of the MS7580

RS232 [◆]		Keyboard Wedge [◆]	
Pin	Function	Pin	Function
1	Signal/Power Ground	1	Signal/Power Ground
2	CTS/DTR Input	2	Tied to Pin 3 in Cable
3	RS232 Receive Input	3	Tied to Pin 2 in Cable
4	No Connect	4	PC Data
5	No Connect	5	PC Clock
6	RTS Output [◇]	6	KB Clock
7	No Connect	7	+5VDC PC Keyboard Power
8	RS232 Transmit Output [◇]	8	KB Data
9	Adapter Power	9	Adapter Power
10	Shield Ground	10	Shield Ground
SHELL	Signal/Power Ground	SHELL	Signal/Power Ground

RS485 [◆]		USB ^{◆◆}	
Pin	Function	Pin	Function
1	Signal/Power Ground	1	Signal/Power Ground
2	CTS	2	Tied to Pin 4 in Cable
3	RXD	3	No Connect
4	PC Data	4	Tied to Pin 2 in Cable
5	PC Clock	5	No Connect
6	KB Clock	6	USB D+
7	Keyboard/USB Power	7	+5VDC USB Power
8	TXD	8	USB D-
9	Adapter Power	9	Adapter Power
10	Shield Ground	10	Shield Ground
SHELL	Signal/Power Ground	SHELL	Signal/Power Ground

- ◆ RS485, RS232, and Keyboard Wedge interfaces require 12V power for operation.
- ◆◆ USB requires 12V power for pass-through functionality.
- ◇ Signals on Pin 6 and 8 are TTL level RS232 output signals.
- ‡ See page 46 for pinout information specific to the MS7580-124-EAS Genesis model.

Standard Cable Pinouts† (Host End)

RS232, 12V VLink Cable 5S-5S000-3	
Pin	Function
1	Shield Ground
2	RS232 Transmit Output
3	RS232 Receive Input
4	No Connect
5	Power/Signal Ground
6	Reserved
7	CTS Input
8	RTS Output
9	+12VDC

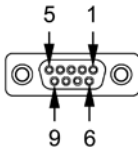

9-Pin Female, D-Type

RS485 MX-RS485-5S006-3	
Pin	Function
1	Signal/Power Ground
2	IBM A+
3	IBM B-
4	+12VDC

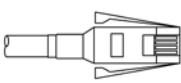

SDL A Key Connector

USB 5S-5S213-3 or 5S-5S006-N-3		
Pin		Function
Type A Non-Locking	Type A Locking Plus-Power	
1	1	PC +5V/V_USB
2	2	D-
3	3	D+
4	4	Ground
	5	Ground
	6	+12VDC
	7-8	No Connect



5S-5S235-N-3



USB Type A Non-Locking





5S-5S213-3

USB Type A Locking Plus-Power

† See page 47 for pinout information specific to the MS7580-124-EAS Genesis model.

Keyboard Wedge VLink Cable 5S-5S002-3		
Pin	Function	 <p>5-Pin DIN, Female</p>
1	Keyboard Clock	
2	Keyboard Data	
3	No Connect	
4	Power Ground	
5	+5VDC	
Pin	Function	 <p>6-Pin DIN, Male</p>
1	PC Data	
2	No Connect	
3	Power Ground	
4	+5VDC	
5	PC Clock	
6	No Connect	

Honeywell will supply an adapter cable with a 5-pin DIN male connector on one end and a 6-pin mini DIN female connector on the other. According to the termination required, connect the appropriate end of the adapter cable to the VLink cable, leaving the necessary termination exposed for connecting to the keyboard and the keyboard port on the PC.

Keyboard Wedge Adapter Cable Supplied with Cable 5S-5S002-3		
Pin	Function	 <p>5-Pin DIN, Male</p>
1	PC Clock	
2	PC Data	
3	No Connect	
4	Power Ground	
5	+5VDC	
Pin	Function	 <p>6-pin Mini DIN, Female</p>
1	Keyboard Data	
2	No Connect	
3	Power Ground	
4	+5VDC	
5	Keyboard Clock	
6	No Connect	



Limited Warranty

Honeywell International Inc. ("HII") warrants its products and optional accessories to be free from defects in materials and workmanship and to conform to HII's published specifications applicable to the products purchased at the time of shipment. This warranty does not cover any HII product which is (i) improperly installed or used; (ii) damaged by accident or negligence, including failure to follow the proper maintenance, service, and cleaning schedule; or (iii) damaged as a result of (A) modification or alteration by the purchaser or other party, (B) excessive voltage or current supplied to or drawn from the interface connections, (C) static electricity or electro-static discharge, (D) operation under conditions beyond the specified operating parameters, or (E) repair or service of the product by anyone other than HII or its authorized representatives.

This warranty shall extend from the time of shipment for the duration published by HII for the product at the time of purchase ("Warranty Period"). Any defective product must be returned (at purchaser's expense) during the Warranty Period to HII factory or authorized service center for inspection. No product will be accepted by HII without a Return Materials Authorization, which may be obtained by contacting HII. In the event that the product is returned to HII or its authorized service center within the Warranty Period and HII determines to its satisfaction that the product is defective due to defects in materials or workmanship, HII, at its sole option, will either repair or replace the product without charge, except for return shipping to HII.

EXCEPT AS MAY BE OTHERWISE PROVIDED BY APPLICABLE LAW, THE FOREGOING WARRANTY IS IN LIEU OF ALL OTHER COVENANTS OR WARRANTIES, EITHER EXPRESSED OR IMPLIED, ORAL OR WRITTEN, INCLUDING, WITHOUT LIMITATION, ANY IMPLIED WARRANTIES OF MERCHANTABILITY OR FITNESS FOR A PARTICULAR PURPOSE, OR NON-INFRINGEMENT.

HII'S RESPONSIBILITY AND PURCHASER'S EXCLUSIVE REMEDY UNDER THIS WARRANTY IS LIMITED TO THE REPAIR OR REPLACEMENT OF THE DEFECTIVE PRODUCT WITH NEW OR REFURBISHED PARTS. IN NO EVENT SHALL HII BE LIABLE FOR INDIRECT, INCIDENTAL, OR CONSEQUENTIAL DAMAGES, AND, IN NO EVENT, SHALL ANY LIABILITY OF HII ARISING IN CONNECTION WITH ANY PRODUCT SOLD HEREUNDER (WHETHER SUCH LIABILITY ARISES FROM A CLAIM BASED ON CONTRACT, WARRANTY, TORT, OR OTHERWISE) EXCEED THE ACTUAL AMOUNT PAID TO HII FOR THE PRODUCT. THESE LIMITATIONS ON LIABILITY SHALL REMAIN IN FULL FORCE AND EFFECT EVEN WHEN HII MAY HAVE BEEN ADVISED OF THE POSSIBILITY OF SUCH INJURIES, LOSSES, OR DAMAGES. SOME STATES, PROVINCES, OR COUNTRIES DO NOT ALLOW THE EXCLUSION OR LIMITATIONS OF INCIDENTAL OR CONSEQUENTIAL DAMAGES, SO THE ABOVE LIMITATION OR EXCLUSION MAY NOT APPLY TO YOU.

All provisions of this Limited Warranty are separate and severable, which means that if any provision is held invalid and unenforceable, such determination shall not affect the validity of enforceability of the other provisions hereof. Use of any peripherals not provided by the manufacturer may result in damage not covered by this warranty. This includes but is not limited to: cables, power supplies, cradles, and docking stations. HII extends these warranties only to the first end-users of the products. These warranties are non-transferable.

The duration of the limited warranty for the MS7580 is two (2) year(s). The accessories have a 90 day limited warranty from the date of manufacture.

Regulatory Compliance

Safety

ITE Equipment

IEC 60950-1:2005, EN 60950-1:2006+A11:2009

LED

LEDs have been tested and classified as “EXEMPT RISK GROUP” to the standard: IEC 62471:2006.

Caution

Use of controls or adjustments or performance of procedures other than those specified herein may result in hazardous radiation exposure. Under no circumstances should the customer attempt to service the LED scanner. Never attempt to look at the LED beam, even if the scanner appears to be nonfunctional. Never open the scanner in an attempt to look into the device. Doing so could result in hazardous radiation exposure. The use of optical instruments with the LED equipment will increase eye hazard.

Atención

La modificación de los procedimientos, o la utilización de controles o ajustes distintos de los especificados aquí, pueden provocar una exposición de luz brillante peligrosa. Bajo ninguna circunstancia el usuario deberá realizar el mantenimiento del LED (Diodo Emisor de Luz) del lector. Ni intentar mirar al haz del LED incluso cuando este no esté operativo. Tampoco deberá abrir el lector para examinar el aparato. El hacerlo puede conllevar una exposición peligrosa a la luz del LED. El uso de instrumentos ópticos con el equipo LED puede incrementar el riesgo para la vista.

Attention

L'emploi de commandes, réglages ou procédés autres que ceux décrits ici peut entraîner de graves irradiations. Le client ne doit en aucun cas essayer d'entretenir lui-même le scanner ou la LED. Ne regardez jamais directement le rayon LED, même si vous croyez que le scanner est inactif. N'ouvrez jamais le scanner pour regarder dans l'appareil. Ce faisant, vous vous exposez à un risque d'irradiation. L'emploi d'appareils optiques avec cet équipement à LED augmente le risque d'endommagement de la vision.

Achtung

Die Verwendung anderer als der hier beschriebenen Steuerungen, Einstellungen oder Verfahren kann eine gefährliche Licht emittierender Dioden strahlung hervorrufen. Der Kunde sollte unter keinen Umständen versuchen, den Licht emittierender Dioden-Scanner selbst zu warten. Sehen Sie niemals in den Licht

emittierender Diodenstrahl, selbst wenn Sie glauben, daß der Scanner nicht aktiv ist. Öffnen Sie niemals den Scanner, um in das Gerät hineinzusehen.

Wenn Sie dies tun, können Sie sich einer gefährlichen Licht emittierender Diodenstrahlung aussetzen. Der Einsatz optischer Geräte mit dieser Laserausrüstung erhöht das Risiko einer Sehschädigung.

Attenzione

L'utilizzo di sistemi di controllo, di regolazioni o di procedimenti diversi da quelli descritti nel presente Manuale può provocare delle rischiose esposizioni radiattive. Il cliente non deve assolutamente tentare di riparare egli stesso lo scanner LED (o diodo emettitore di luce). Non guardate mai il raggio LED (d. emettitore di luce), anche se credete che lo scanner non sia attivo. Non aprite mai lo scanner per guardare dentro l'apparecchio. Facendolo potete esporVi ad una radiazione rischiosa. L'uso di apparecchi ottici, equipaggiati con raggi LED (d. emettitori di luce), aumenta il rischio di danni alla vista.

EMC

Emissions

FCC Part 15, ICES-003, CISPR 22, EN 55022

Immunity

CISPR 24, EN 55024

Changes or modifications not expressly approved by the party responsible for compliance could void the user's authority to operate the equipment.

Class A Devices

The following is applicable when the scanner cable is greater in length than 3 meters (9.8 feet) when fully extended:

Les instructions ci-dessous s'appliquent aux cables de scanner dépassant 3 mètres (9.8 pieds) de long en extension maximale:

Folgendes trifft zu, wenn das Scannerkabel länger als 3 Meter ist:

This equipment has been tested and found to comply with limits for a Class A digital device, pursuant to part 15 of the FCC Rules. These limits are designed to provide reasonable protection against harmful interference when the equipment is operated in a commercial environment. This equipment generates, uses and can radiate radio frequency energy and, if not installed and used in accordance with the instruction manual, may cause harmful interference to radio communications. Operation of this equipment in a residential area is likely to cause harmful interference, in which case the user will be required to correct the interference at their own expense. Any unauthorized changes or modifications to this equipment could void the user's authority to operate this device.

This device complies with part 15 of the FCC Rules. Operation is subject to the following two conditions: (1) This device may not cause harmful interference, and (2) this device must accept any interference received, including interference that may cause undesired operation.

Notice

This Class A digital apparatus complies with Canadian ICES-003.

Remarque

Cet appareil numérique de classe A est conforme à la norme canadienne NMB-003.

European Standard

Warning

This is a class A product. In a domestic environment this product may cause radio interference in which case the user may be required to take adequate measures.

Warnung!

Dies ist eine Einrichtung der Klasse A. Diese Einrichtung kann im Wohnbereich Funkstörungen verursachen. In diesem Fall kann vom Betreiber verlangt werden, angemessene Massnahmen durchzuführen.

Attenzione

Questo e' un prodotto di classe A. Se usato in vicinanza di residenze private potrebbe causare interferenze radio che potrebbero richiedere all'utilizzatore opportune misure.

Attention

Ce produit est de classe "A". Dans un environnement domestique, ce produit peut être la cause d'interférences radio. Dans ce cas l'utilisateur peut être amené à prendre les mesures adéquates.

Changes or modifications not expressly approved by the party responsible for compliance could void the user's authority to operate the equipment.

Class B Devices

The following is applicable when the scanner cable is less than 3 meters (9.8 feet) in length when fully extended:

Les instructions ci-dessous s'appliquent aux câbles de scanner ne dépassant pas 3 mètres (9.8 pieds) de long en extension maximale:

Folgendes trifft zu, wenn das Scannerkabel kürzer als 3 Meter ist:

This device complies with Part 15 of the FCC Rules. Operation is subject to the following two conditions: (1) This device may not cause harmful interference, and (2) this device must accept any interference received, including interference that may cause undesired operation.

This equipment has been tested and found to comply with the limits for a Class B digital device, pursuant to Part 15 of the FCC rules. These limits are designed to provide reasonable protection against harmful interference in a residential installation. This equipment generates, uses and can radiate radio frequency energy and, if not installed and used in accordance with the instructions, may cause harmful interference to radio communications. However, there is no guarantee that interference will not occur in a particular installation. If this equipment does cause harmful interference to radio or television reception, which can be determined by turning the equipment off and on, the user is encouraged to try to correct the interference by one or more of the following measures:

- Reorient or relocate the receiving antenna
- Increase the separation between the equipment and receiver
- Connect the equipment into an outlet on a circuit different from that to which the receiver is connected
- Consult the dealer or an experienced radio/TV technician for help

Notice

This Class B digital apparatus complies with Canadian ICES-003.

Remarque

Cet appareil numérique de classe B est conforme à la norme canadienne NMB-003.

Index

A

AC 2, 7–11, 30
Accessories 2
Adapter 2, 13, 14, 45
Aperture 4
Audible Indicator 20–21, 34
Automatic Activation Mode 17

B

Bar Code 23, 25–28, 29, 33
Beep 20–21, 25–28, 29, 34
Blue LED 4, 7–11, 20–21, 34
Button 4, 17, 18, 20, 33

C

Cable 6
 Keyboard Wedge 3, 8, 44–45
 RS232 3, 7, 44–45
 RS485 3, 9, 44–45
 Termination 4
 USB 3, 10, 11, 44–45
 VLink.. 2, 3, 7–11, 25–28, 34, 44–45
Caution 7–11, 49
CE 5, 7–11
Code Type 17, 18, 23, 30
Compliance 7–11, 48, 49–52
Configuration 25–28, 31, 33, 34
Connector Pinouts 43
Current 30
Customer Service 2, 3, 48

D

DC 2, 30, 43, 44–45
Decode 29
Default Parameters 31
Depth of Field 23

E

EAS 39, 40
EMC 30, 50, 52
EMI 50
Emissions 50, 52

F

Field of View 22
Firmware 34
Flash ROM 34

H

Host 7–11

I

Immunity 50, 52
Indicator
 Audible 4, 20–21, 29, 34
 Failure 4, 20–21
 Visual 4, 20–21, 29, 34
Interface 25–28, 29
 Cable 7–11, 44–45
 Keyboard Wedge... 1, 3, 8, 31, 43
 RS232 1, 3, 7, 31, 43
 RS485 3, 9, 31, 43
 USB 3, 10, 11, 31, 43
IR 17, 24

K

Keyboard Country Type 31
Keyboard Type 31

L

Labels 5
LED 7–11, 25–28, 29
 Blue 7–11, 20–21
 White 7–11, 20–21
License 17, 18
Light Levels 30
Light Source 29

M

Maintenance 5
Manual Activation Mode 17, 18
Manuals 2
MetroSelect 33
MetroSet2 34

P

Pass-Through.....	17
Pinouts	43, 44–45
Power	7–11, 30, 34
Power Supply	6, 7–11
Presentation	17
Protocols	31

R

Razz	20–21, 25–28
Repair.....	48
RMA	48

S

Safety	49
SELV	7–11
Service	48
Specifications	
Electrical	30
Environmental.....	30
Mechanical.....	30
Operational	29

Swiftdecoder™	1
---------------------	---

T

Tone.....	20–21
Transformer	2, 7–11, 30
Troubleshooting	25–28

U

UL	5, 7–11
Upgrade	34

V

Ventilation	30
Visual Indicator	20–21, 34
Voltage.....	30

W

Wall Mount.....	13–16
Warranty	48
White LED.....	4, 7–11, 20–21, 34
Window	4, 5

Customer Support

Technical Assistance

If you need assistance installing or troubleshooting your device, please call your distributor or the nearest technical support office:

North America/Canada

Telephone: (800) 782-4263

E-mail: hsmnasupport@honeywell.com

Latin America

Telephone: (803) 835-8000

Telephone: (800) 782-4263

E-mail: hsmlasupport@honeywell.com

Brazil

Telephone: +55 (11) 5185-8222

Fax: +55 (11) 5185-8225

E-mail: brsuporte@honeywell.com

Mexico

Telephone: 01-800-HONEYWELL (01-800-466-3993)

E-mail: soporte.hsm@honeywell.com

Europe, Middle East, and Africa

Telephone: +31 (0) 40 7999 393

Fax: +31 (0) 40 2425 672

E-mail: hsmeurosupport@honeywell.com

Hong Kong

Telephone: +852-29536436

Fax: +852-2511-3557

E-mail: aptechsupport@honeywell.com

Singapore

Telephone: +65-6842-7155

Fax: +65-6842-7166

E-mail: aptechsupport@honeywell.com

China

Telephone: +86 800 828 2803

Fax: +86-512-6762-2560

E-mail: aptechsupport@honeywell.com

Japan

Telephone: +81-3-6730-7344

Fax: +81-3-6730-7222

E-mail: aptechsupport@honeywell.com

Online Technical Assistance

You can also access technical assistance online at www.honeywellaidc.com.

Product Service and Repair

Honeywell International Inc. provides service for all its products through service centers throughout the world. To obtain warranty or non-warranty service, contact the appropriate location below to obtain a Return Material Authorization number (RMA #) before returning the product.

North America

Telephone: (800) 782-4263

E-mail: hsmnaservice@honeywell.com

Latin America

Telephone: (803) 835-8000

Telephone: (800) 782-4263

Fax: (239) 263-9689

E-mail: laservice@honeywell.com

Brazil

Telephone: +55 (11) 5185-8222

Fax: +55 (11) 5185-8225

E-mail: brservice@honeywell.com

Mexico

Telephone: 01-800-HONEYWELL (01-800-466-3993)

Fax: +52 (55) 5531-3672

E-mail: mxservice@honeywell.com

Europe, Middle East, and Africa

Telephone: +31 (0) 40 2901 633

Fax: +31 (0) 40 2901 631

E-mail: euroservice@honeywell.com

Hong Kong

Telephone: +852-29536436

Fax: +852-2511-3557

E-mail: apservice@honeywell.com

Singapore

Telephone: +65-6842-7155

Fax: +65-6842-7166

E-mail: apservice@honeywell.com

China

Telephone: +86 800 828 2803

Fax: +86-512-6762-2560

E-mail: apservice@honeywell.com

Japan

Telephone: +81-3-6730-7344

Fax: +81-3-6730-7222

E-mail: apservice@honeywell.com

Online Product Service and Repair Assistance

You can also access product service and repair assistance online at www.honeywellaidc.com.

Honeywell Scanning & Mobility

9680 Old Bailes Road

Fort Mill, SC 29707

www.honeywellaidc.com



GEN-7580-UG Rev C
10/11